

GL4800

The newest generation of the tried and tested thoroughbred **GL4000**. Flexible and multi-tasking, it is equipped to deal with any number of live sound and recording tasks. Bristling with configurable mode switches and the optimum combination of 10 auxes and 4 matrix, this console can adapt quickly to the toughest sound mixing challenges.

GL4000 is a large format, multi-function, LR, M, 8 group, 10 aux, 11x4 matrix console. Frame sizes range from 24 to 48 channels, with A,B,C,D options for more stereo channels.

A = all mono channels
B = 4 stereos to right of masters
C = 4 stereos on far right side
D = 8 stereos on far right side



FEATURES

- ▶ 24, 32, 40, 48 channel frames
- ▶ A,B,C,D mono/stereo channel options
- ▶ Multi-functionality for FOH/Monitor mixing and live recording
- ▶ LR and M main mixes
- ▶ 8 Audio groups with pan and routing to LR and M
- ▶ 11x4 Matrix
- ▶ 10 Auxiliary sends with faders, inserts and XLR
- ▶ Aux 10 can provide channel direct output pre/post and level trim
- ▶ Group out pre/post switching and level trim for recording
- ▶ Per channel pre/post fader aux switching for unlimited flexibility
- ▶ Second (LR2) output with pre/post fader selection and level trim
- ▶ Output reverse mode to swap aux inserts and XLR with matrix and LR2
- ▶ 2-track replay to LR and monitor
- ▶ Stereo channel line inputs can be assigned independently to LR
- ▶ 4 band, 4 sweep EQ with switched Q on midrange
- ▶ Swept 20-400Hz high pass filters
- ▶ Unique matrix to aux link for quick monitors and grouped effects
- ▶ 128 snapshot memory mute automation with preview and safes functions
- ▶ 8 Mute groups or scenes
- ▶ Solo-in-Place with toggle last and safes
- ▶ Single press clear or set all mutes function
- ▶ Mutes on all fader masters
- ▶ Meters on all buses to warn of mix overload
- ▶ Simultaneous metering of the groups, LRM and auxes
- ▶ Integral LED-illuminated moving coil VU meterpod
- ▶ Simultaneous LED bar and moving coil VU monitor metering
- ▶ Mono/stereo PFL with trim
- ▶ PFL override AFL for logical input/output monitoring
- ▶ Engineer's wedge fader control in monitor mode
- ▶ Separate headphones and local outputs
- ▶ Talkback to LR, M, groups, matrix, and to each aux
- ▶ Electronically balanced XLR outputs with +26dBu drive capability
- ▶ Preamp input capability for mic or line up to +34dBu
- ▶ Ultra low noise mix head amp design
- ▶ Balanced inserts with separate send and return sockets
- ▶ 100mm, premium grade dual rail faders as used on the top-of-the-range ML Series
- ▶ 4-pin XLR lamp sockets – **ALLEN & HEATH** LEDlamp available
- ▶ Individual circuit card assembly with nutted pots
- ▶ Uses RPS11 high performance external linear power supply
- ▶ Built-in combiner for redundant backup power supply
- ▶ Sys-Link V2 input linking option for adding a slave console



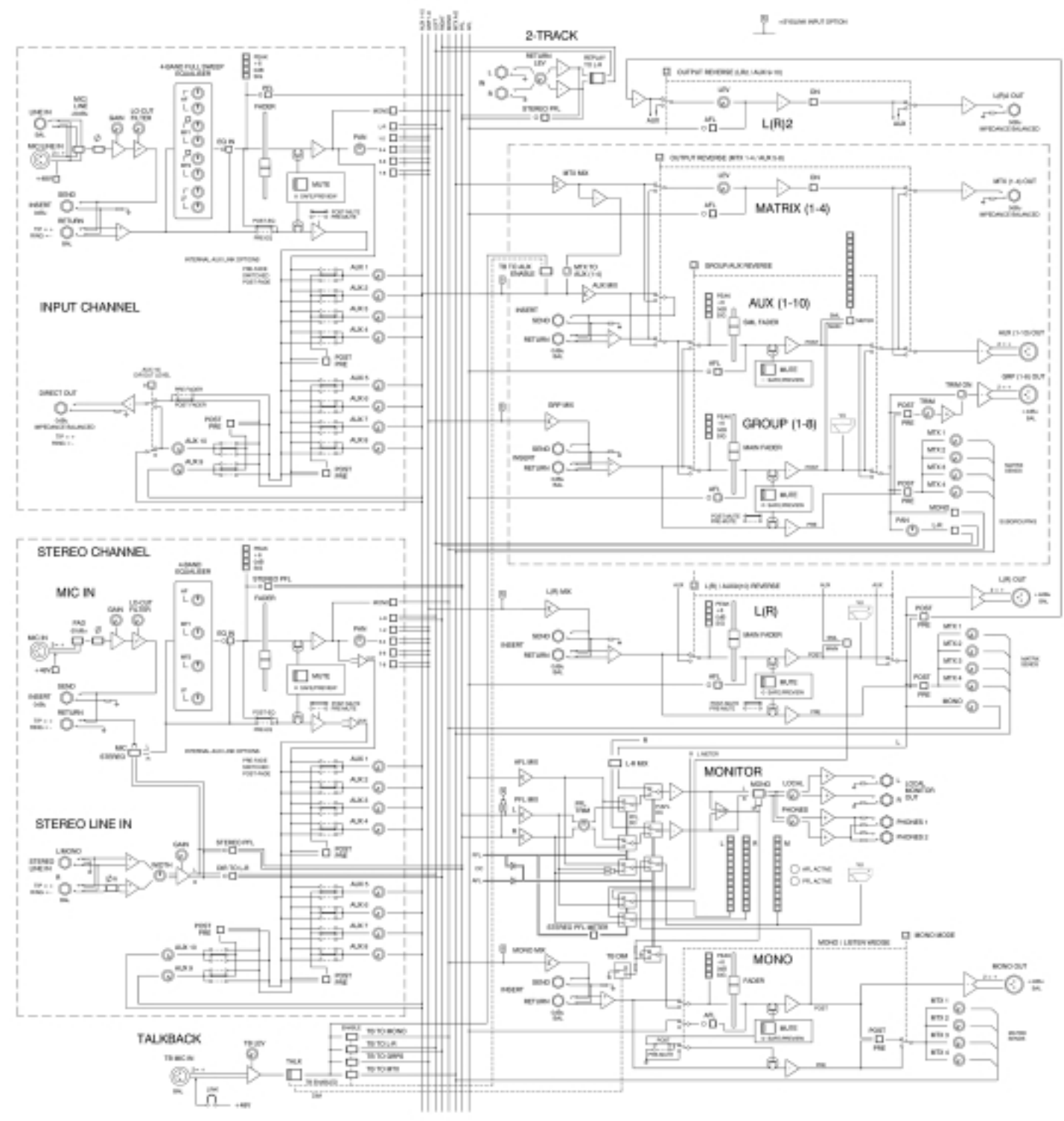

GL4800
System Block Diagram