



115UM™

15" TWO-WAY HIGH OUTPUT SOUND REINFORCEMENT SYSTEM / UTILITY MONITOR

ONE SYSTEMS®

The 115UM™ is a 15 inch two way high output sound reinforcement system. The enclosure geometry allows the 115UM for be used as either a utility enclosure or a high output floor monitor. The 115UM may be used in outdoor installations as well as indoor applications where high intelligibility and accuracy are required. Like all ONE SYSTEMS® products, the 115UM was designed to not only offer excellent full range fidelity but superior vocal reproduction and intelligibility as well. The system consists of a single 15 inch 15I/O woofer and an ETS driver on a fully rotatable high frequency horn.

The ONE SYSTEMS 115UM features an 18mm birch plywood enclosure that utilizes stainless steel internal structural supports to enable a variety of suspension points when it is used in a "utility" mode. The 45 degree angle also makes the 115UM an ideal floor monitor for professional applications. Because of its small size, the 115UM also features an integral stand/pole mount adaptor.

The grill is a 3 layer "rain shield" design that will minimize direct rain contact with the systems transducers. All internal and external metal hardware, as well as the grill, are stainless steel. The enclosure and grill design are rated to IEC 529 IP45 (solid object penetration to 1 mm (0.04 inches) and water jets from any direction). The enclosures and components are also rated to Mil Spec 810.

The input section consists of both 4 pin Neutrik Speakons as well as a stainless steel hardware barrier strip. A weather cover is provided with an integral gland nut connector for outdoor applications. In the outdoor configuration connections are made thru the 4

position barrier strip. The input is user switchable for either full range or bi amp operation. The switch is located on the input plate and is isolated from direct weather by the weather cover.

The Gland nut is weather proof and is rated NEMA 6P (IP68). The connector will accommodate cable outside diameters from 7mm to 12mm (0.236" to 0.472"). The maximum diameter will accommodate most 2 conductor AWG 12 cable assemblies.

The basic design utilizes a patent pending high frequency driver and horn combination. . The fully rotatable high frequency horn has a pattern of 105 degrees by 60 degrees. The ETS design offers extended bandwidth polar control and very low distortion. The ETS-105/60 is a 105 degree horizontal by 60 degree vertical pattern and may be rotated to also provide a 60 degree horizontal by 105 degree vertical for short throw and downfill applications.

The patent pending ET-2 large format driver (full details are available at the ONE SYSTEMS web site, www.ONE-SYSTEMS.com) is a unique "equivalent throat" design that allows the radiation pattern to be controlled by the phase plug summation plane rather than the conventional "exit diameter" at the end of the driver structure. This feature provides extended high frequency dispersion. The ET-2 large format driver has a titanium diaphragm and a close spaced circumferential ring phase plug to insure extended high frequency bandwidth.

The low frequency design is also patent pending. The 15 inch I/O woofer (Inside Only) utilizes a unique voice coil wind on the inside of the voice coil support structure. This design allows

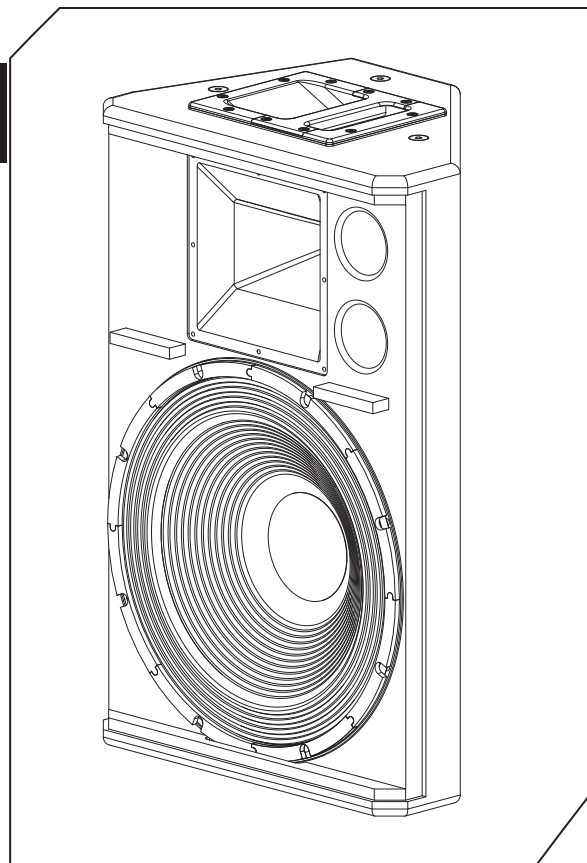

FEATURES AND BENEFITS

- Weather Resistant 15" two-way system.
- Multi angle Enclosure Geometry
- Designed as either a Utility Enclosure or Floor Monitor
- Integral Stand/Pole adaptor
- Optimized for high intelligibility and vocal articulation.
- ETS Fully rotatable high frequency horn.
- Patent Pending large voice coil low frequency transducer.
- Multiple M10 flying points.
- Gland Nut and Speakon inputs
(Weather cover for Gland nut installations).

SPECIFICATIONS

Frequency Response:	65Hz – 16kHz
Coverage Pattern:	105H x 60V (ET105/60)
Passive Crossover Frequency:	1800 Hz (ETS 105/60)
Externally Switchable Bi-amp / Full Range:	See website for crossover presets
Inputs:	4 position barrier or 2 each 4 pin Speakon
System Sensitivity: (1 watt-1 meter)	96dB
Power Handling:	800 watts Continuous 1600 watts Program 3200 watts Peak*
* All power handling ratings are amplifier headroom dependent	
Nominal Impedance:	8 ohms

Speakon® is a registered trademark of Neutrik®



115UM™

ONE SYSTEMS®

for both high magnetic system displacement as well as increased thermal transfer. This results in reduced power compression and higher reliability.

Because the ONE SYSTEMS 115UM is designed for both floor monitor and permanent installation applications a variety of rigging and suspension options are available. The 115UM has 12 M10 mounting points. An M10 forged shoulder eye bolt kit is available for all M10 suspension points.

SYSTEM SPECIFICS

Low Frequency:	ONE SYSTEMS 15 I/O
High Frequency:	ONE SYSTEMS ET Driver
System Tunings (Bi-amp mode):	www.ONESYSTEMS.com
EASE 4.0 data	www.ONESYSTEMS.com
Suspension/Mounting points:	12 each M10 Integral Stand/Pole adaptor
Weather Performance:	IEC 529 IP 45 Mil Spec 810
Dimensions (H x W x D):	698mm x 444.5mm x 323.9mm (27.48 in x 17.5 in x 12.75 in)
Net Weight:	26 kg (57.3 lb)
Optional Accessories:	M10 Forged Shoulder Eye Bolt

